



No Septic

No Odour

No Water

Waterless Composting Toilets

Advanced Swedish Technology





Advanced Swedish Technology

Manufactured for over 35 years in Sweden, the MullToa Waterless Composting Toilet family includes three electric models and one non-electric model. A world leader in composting toilet technology, Mulltoa toilets are available in 17 countries. Continual advancements over the decades ensures the MullToa toilets are the best in the world.

With neither drain nor water to connect, the MullToa 60, MullToa 45 and MullToa 20 are absolutely the most advanced Waterless Composting Toilets. With many progressive European features, these fully automatic models will provide years of trouble-free service with very simple maintenance. Designed for home, cottage, cabin, boathouse or bunkie.

MullToa 60 is the only Eco Certified (Nordic Eco Label - Svan Certified) **composting toilet in North America.**

Why Eco Certified?

Eco Certification provides third party information that enables consumers to select products that are the least harmful to the environment. The MullToa 60 testing and evaluation took place in both the laboratory and field-testing. The test was done by an independent and specially selected test facility at the University of Agriculture in Norway. This is the most extensive testing in the world.

This extensive testing requires a closed toilet system to be “a toilet that is not connected to a drainage system for receiving faeces and urine”. Without a drain, the toilet must handle waste from four people in a permanent use situation (with no drain installed), and the end product must be safe and utilized as a means of soil improvement.



MullToa 60 Certified and Tested For:

Capacity + Performance: MullToa 60 was tested to handle waste from four people using the toilet permanently (5 toilet uses per person per day) and several periods of double usage.

Environment: The finished compost is tested to ensure it is hygienic to handle and environmentally safe. Strict limits are set regarding allowable amounts of remaining bacteria (less than 2 coli form/gram), salts & nutrients.

Odour: No odours indoors or outside on or near the ground.

Material Quality: Mechanical and electrical components, leak proof operation, ventilation and wear etc.

Maintenance: Must be easy to service and hygienic.

Electrical: The power usage must be within specific parameters with maximum of 320W

Test conducted at the University of Norway

Added During The Test:

336 liters of urine

60 rolls of toilet paper

51.2kg of solid waste

Next:

Humus tray was then emptied and contents measured.



Look What Happened in 8 weeks!

Result:

All that remained was approximately 12 liters of composted material, pictured here in the humus tray.

MullToa 60

Fully Automatic

4 people full time use

6 people part time use

No drain or step

Electrical requirements:

120V, 60Hz, 310W max

Dimensions:

H 66cm x W 65cm x D 81cm

(H 26in x W 25.5in x D 32in)

Floor space required:

(to allow compost tray to be emptied)

W 65cm x D 135cm

(W 25.5in x D 54in)

Seat Height:

50cm (19.5in)

MullToa 60 is fully automatic, has a large upper composting chamber, two heating elements, ventilation fan, advanced mixing mechanism, and excess liquid sensor making it the most advanced composting toilet in the world.

MullToa 60 has passed the most extensive testing worldwide to certify a toilet.

Tested for quality, environmental responsibility, functionality and performance. Patented.

The only eco certified closed-system composting toilet in North America.

MullToa 45

Fully Automatic

3 people full time use

4 people part time use

No drain or step

Electrical requirements:

120V, 60Hz, 310W max

Dimensions:

H 65cm x W 55cm x D 71cm

(H 26in x W 22in x D 28in)

Floor space required:

(to allow compost tray to be emptied)

W 55cm x D 110cm

(W 22in x D 44in)

Seat Height:

50cm (19.5in)

The elegant fully automatic MullToa 45 decorates any bathroom with style. MullToa 45 is identical to MullToa 60 except for capacity and is the perfect choice when you need a compact design. Simply lower the seat after each use and your MullToa 45 does the rest! Patented.



MullToa 20

Fully Automatic

3-4 people part time use

No drain or step

Electrical requirements:

120V, 60Hz, 310W max

Dimensions:

H 66cm x W 55cm x D 74cm
(H 26in x W 22in x D 30in)

Floor space required:

(to allow compost tray to be emptied)
W 55cm x D 110cm
(W 22in x D 44in)

Seat Height:

50cm (19.5in)

Equipped with a single heating element, advanced mixing mechanism, fan and adjustable thermostat, the MullToa 20 has all the basics for great composting. This economy model is the perfect solution for lower use locations.

Usage is based on five toilet uses per person per day.

*'Full time' means year round
'Part time' means up to five consecutive days.*

MullToa 10

Semi Automatic

3-4 people part time use

No drain or step

Electrical requirements:

120V, 60Hz, 250W max

Dimensions:

H 66cm x W 55cm x D 74cm
(H 26in x W 22in x D 30in)

Floor space required:

(to allow compost tray to be emptied)
W 55cm x D 110cm
(W 22in x D 44in)

Seat Height:

50cm (19.5in)

The MullToa 10 is our most economical electric toilet. Perfect for a lower use location. Identical to the MullToa 20 with the exception of the mixing mechanism. The MullToa 10 has a manual mixer located on top of the toilet. Simply turn the 'T' handle a couple of times after each use and your compost is mixed and aerated.



How it works

The closed-system Mulltoa is a fully automatic toilet that anticipates your every move! Sitting on the toilet seat opens the trap doors; closing the toilet seat lid activates the stainless steel mixing mechanism that efficiently breaks down paper and distributes moisture into the compost material in the upper chamber. Material in the upper chamber is finished in the lower chamber and eventually emptied into a garden composter. The non-composted portion and the dry, composted portion are kept separate.

A fan circulates warm air under and around the compost for fast decomposition and evaporation of liquid. A float switch operates an additional heater (MullToa 60 & 45) if excess liquid is detected. Once a week or as needed, mulch is added through the toilet seat opening.

Using efficient Swedish technology electrical consumption is very low with an adjustable thermostat, which is set according to the number of people using the toilet. When you are away for more than two days, just turn your MullToa off!

Without any water or drain to connect MullToa toilets can be easily installed anywhere.

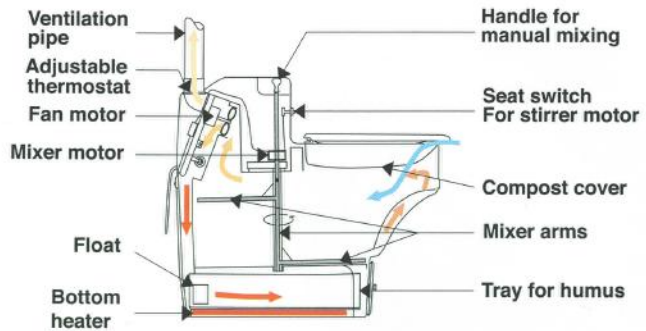

Easy to Clean

Made from durable polished polystyrene plastic MullToa toilets have a very smooth design and are extremely easy to keep clean. The toilet seat can be easily removed with a gentle pull.



Empty the Humus Tray Once a Year!

Usage and local temperature will determine the actual frequency, but in a part time vacation home or cottage annual removal of the compost is usually more than enough.

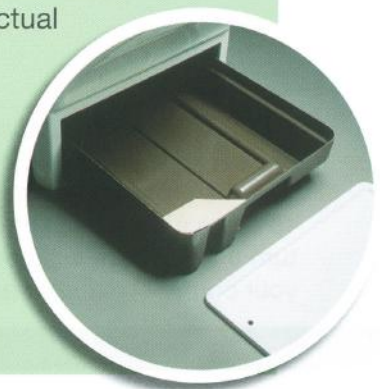

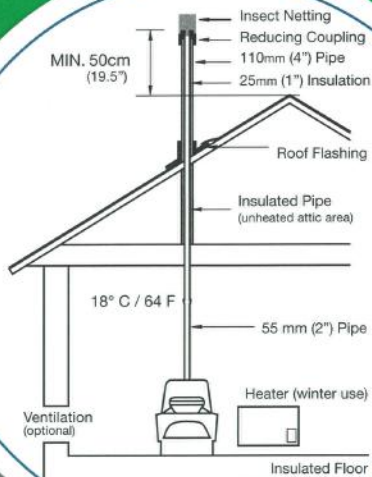

Installation is Easy!

The average handy person can install a MullToa toilet in a couple of hours with common household tools. Each unit comes with a standard installation kit and detailed instructions. Simply follow the instructions and install the ventilation pipe through the roof, pour the Mulch into the toilet and plug the unit into a 120V AC outlet.



Included with each MullToa Toilet:

Installation Kit

(8 ft interior vent pipe, 4 ft exterior vent pipe, roof flashing, reducing coupling, insect netting)

Installation & Instruction Manual

20L bag of Starter Mulch

Manual mix rake

Warranty:

Limited 3 year parts replacement on electrical components

Limited 5 year parts replacement on remaining components

Limited 25 year parts replacement on body (top, base, and tray door)



At EcoEthic we value a healthy environment and care about a healthy planet.

EcoEthic products are proven ecological solutions for everyday living. Whether it's biodegradable, phosphate & chlorine free cleaning products; leading edge eco-certified non-toxic septic & drain treatments; or the worlds most advanced waterless composting toilets, EcoEthic Inc. has quality products that help protect our environment.

EcoEthic Quality Environmental products include:

Waste Treatment

Septic System Treatment | Holding Tank Treatment | BioSurge Outhouse Treatment

MullToa Toilet Accessories

Venting | Starter Mulch | 12v Fan

Septic Safe Cleaning Products

Drain Cleaner (non-toxic & caustic free) | Automatic Dishwashing Powder (phosphate & chlorine free)
Laundry Detergent | Dishwashing Liquid | All Purpose Cleaner | Cream Cleaner | Hand & Body Wash



printed on recycled paper

Perth & District Septic Service Ltd.

2762 Drummond Con. 7, R.R. #6
Perth, ON K7H 3C8

613-267-3350

info@perthseptic.com
www.perthseptic.com